

AIR EXHAUST VENTS
 PROVIDE MINIMUM 12"
 SPACE AT REAR OF SWITCH.

BACK OF ENCLOSURE

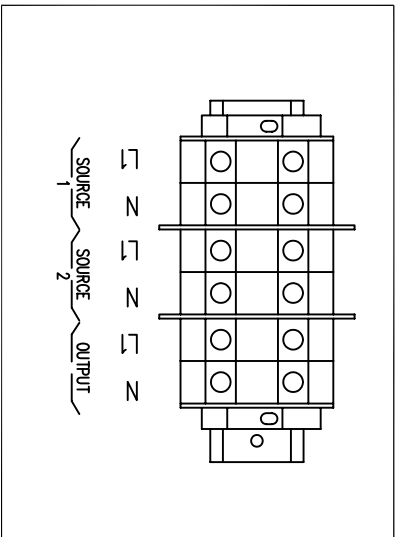

COVER PLATE

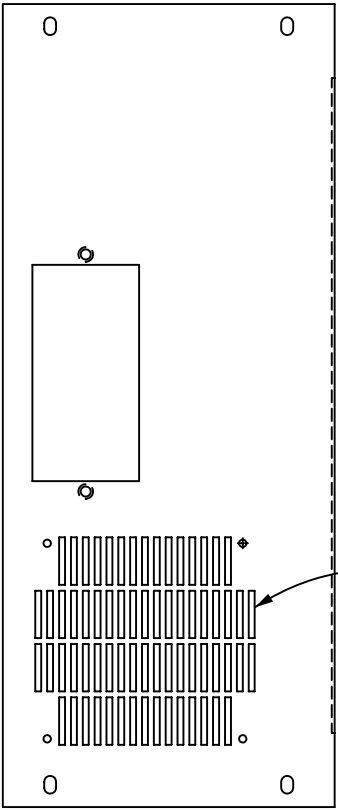
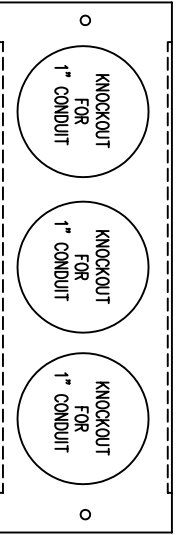

AC INPUT VOLTAGE	CONNECT TO	OUTPUT	CONNECT TO
120V	L1 & (N NEUTRAL)	120V	L1 & N

INSTALLER CONNECTIONS
 100 AMP, 1 POLE
 STATIC SWITCH

IC4866-580

SHEET 2 OF 3

ISSUE

100 AMP, 1 POLE STATIC SWITCH

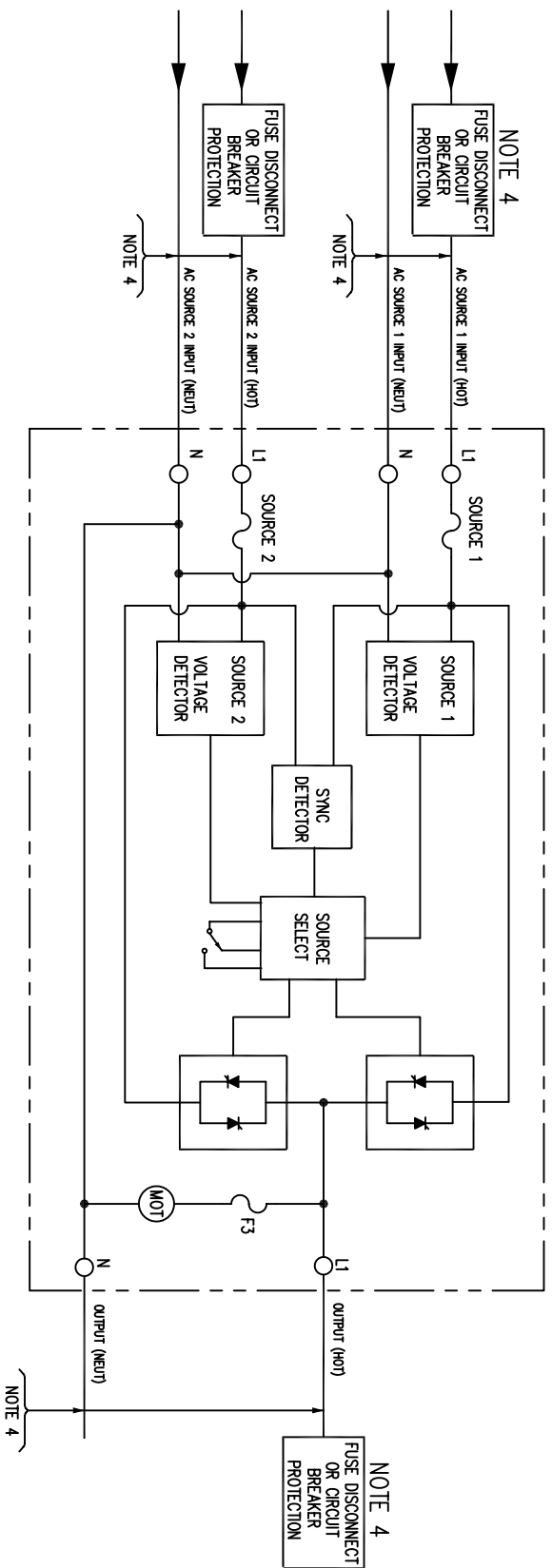

- NOTES:
- 1 WIRE SIZE RECOMMENDATIONS BASED ON 90°C COPPER CONDUCTORS OPERATING IN 30°C AMBIENT AND NEC TABLES 290-95 & 310-16, INCREASE CONDUCTOR SIZE FOR LONG RUNS.
 - 2 ALL FIELD WIRING TO BE COPPER CONDUCTOR ONLY.
 - 3 ALL GROUNDS SHOWN SHALL BE CONNECTED SEPARATELY TO A SINGLE GROUNDING POINT AT THE SOURCE SERVICE EQUIPMENT, PER IEEE STD. 446-1980 FIG. 72.
 - 4 FUSE OR CIRCUIT BREAKER PROTECTION EXTERNAL TO UPS TO BE PROVIDED BY CUSTOMER. SEE TABLE BELOW FOR RECOMMENDED PROTECTION SIZING AND WIRE SIZING.
 - 5 SPECIFIED TORQUE VALUES ARE FOR INTERNAL WIRING CONNECTIONS ONLY.

AC SOURCE 1 AND 2 INPUTS						OUTPUT									
TERM. No. (L1,N)						TERM. No. (L1,N)									
SIZE	SPEC. No.	AC INPUT	MAX. INPUT CURRENT	TERM. CAPACITY	TORQUE	RECM. SIZE	RECM. FUSING	RECM. GRD. SIZE	OUTPUT VOLTAGE	FULL LOAD CURRENT (AMPS)	TERM. CAPACITY	TORQUE	RECM. SIZE	RECM. GRD. SIZE	RECM. FUSING
100 AMP	4866-580	120	100 AMPS	8-0 AWG	35 IN/LB	2 GA	125A	8 GA.	120V	100 AMP	8-0 AWG	35 IN/LB	2 GA.	8 GA.	125 AMP