



Industrial 120VDC 3 & 5 KVA UPS

Series 1000 Harsh Environment UPS Standard Features

- True On-line Technology for Maximum Power Protection
- Full kW-Rated Output Supports Any Power Factor Load - No Need To Oversize
- Full Input to Output Load Isolation
- Generator Compatible Rectifier Input
- Fast Recovery Industrial Grade Charger
- High Efficiency Transistorized PWM Inverter
- Pure Sine Wave Output
- Less Than 1% Output THD
- Automatic "Zero Break" Transfer Switch
- Capable of Powering High-Inrush Loads
- Handles Nonlinear Loads With Up To 5:1 Crest Factors
- Load-rated at 50°C For Tough Industrial-Grade Protection
- NEMA12K Cabinet with Gaskets and Reusable Air Filters
- Variable Speed, Temperature and Load Sensitive Cooling System For Quiet Operation
- 20-year Design Life
- User-Friendly Display Panel
- Internal Maintenance Bypass Switch
- Heavy Duty Floor Mount Brackets
- Built to Meet UL1778, NEMA, NEC, ANSI and FCC requirements



OPTIONS

- ⇒ Multiple Voltage Inputs/Outputs Available
- ⇒ 50Hz/60Hz Models
- ⇒ External Maintenance Bypass Switch
- ⇒ Form C Alarm Contacts
- ⇒ Digital Meter Panel
- ⇒ Dual Input Kit
- ⇒ Ethernet Communication
- ⇒ Customizable Designs for Unique Applications

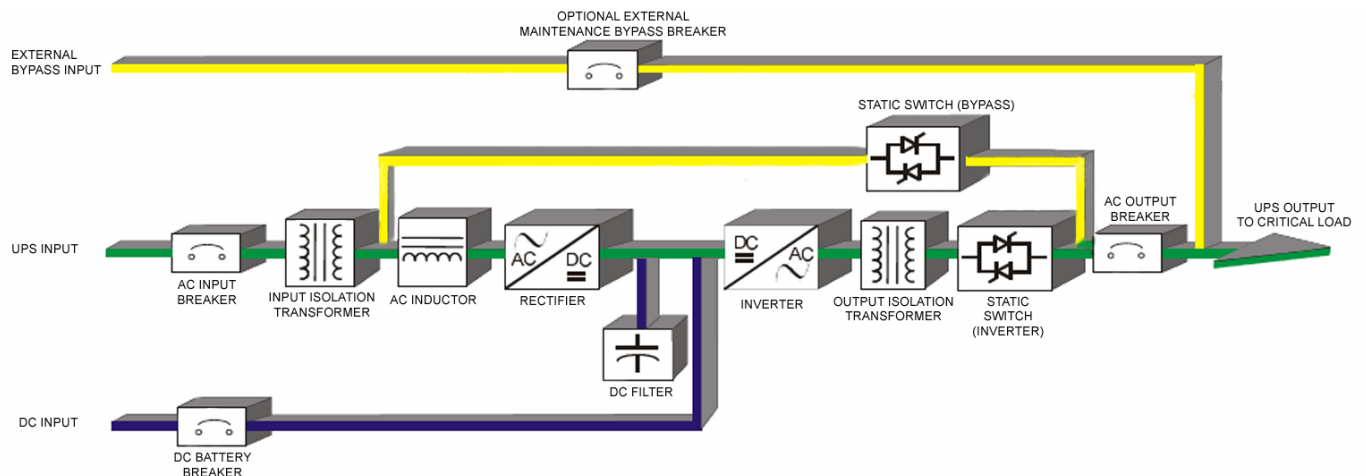



Industrial 120VDC 3 & 5 KVA UPS

Technical Specifications								
AC INPUT								
Model	LT1030H 3kva \ 3kw				LT1050H 5kva \ 5kw			
Nom. Rectifier Volts 1-Ph (V)	120	208	240	480	120	208	240	480
Max Current (A)	35.7	24.3	21	10.5	62	40.1	35.4	17.7
Max. Current w/ Recharge	45.7	29	26.1	15.1	66.6	45.3	39.7	21.2
Protection (Breaker Amps)	50	32	32	25	70	50	50	25
Input Voltages (V)	120, 208, 220, 230, 240, 440, 460, 480				120, 208, 220, 230, 240, 440, 460, 480			
Voltage Acceptance Range	Nominal $\pm 15\%$ and remain operational							
Frequency	50 / 60 Hz							
Power Walk-In	5 sec. to full load							
AC OUTPUT								
Power Rating (@ 40°C/50°C)	3.75kva (3kw) / 3kva (2.4kw)				6.25kva (5kw) / 5kva (4kw)			
Nominal Voltage 1Ph (V)	120	208	240		120	208	240	
Nominal Current (A)	25	14.5	12.5		42	24	21	
Frequency (Hz)	50 / 60Hz (Bypass freq. must match output freq.)							
Load Power Factor	Any							
Steady State Regulation	$\pm 1\%$ over full input, power factor, temperature and load range							
Dynamic Regulation	$\pm 2\%$ from nominal for 100% step load							
Harmonic Distortion	1% RMS max, for linear loads							
Load Crest Factor	5:1							
Overload Current @ 0.8 PF Load	110% Indefinitely							
	125% for 10 minutes							
	150% for 60 seconds							
Overload Current @ 1.0 PF Load	120% for 15 seconds							
	125% for 8 seconds							
Frequency Stability	$\pm 0.01\%$ for nominal							
Slew Rate	1 Hz/sec max							
Sync Window	58.8 to 61.2 Hz ($\pm 2\%$)							
SYSTEM EFFICIENCY								
1-Ph. Input (Half/Full Load)	76% / 76%				79% / 79%			
ENVIRONMENT								
Operating Temperature	32°F to 122°F (0°C to 50°C)							
Storage Temperature	-4°F to 140°F (-20°C to 60°C)							
Heat Dissipation (BTU/Hr)	2,000				2,900			
Humidity	0 – 90% non-condensing							
Audible Noise	< 65 dB(A) Scale @ 1 meter							
ENCLOSURE								
Model	LT1030H				LT1050H			
Dimensions	35"H x 18.75"W x 31"D				35"H x 18.75"W x 31"D			
Weight (lbs) w/o batt.	365				465			
Color	ANSI 61 Gray							
Cable Entry	Top Rear							
Rating	NEMA 12K							

Note: All data is subject to change without notice.