

PHYSICAL INSTALLATION

1 POSITION INVERTER ENCLOSURE IN 19" OR 23" RACK AND SECURE WITH 12-24 SCREWS AND HARDWARE (8 PLACES).

GENERAL NOTES:

- 1 ALL DIMENSIONS ARE IN INCHES UNLESS OTHERWISE SPECIFIED. DIMENSIONS WITHIN BRACKETS [] ARE IN CENTIMETERS.
- 2 WIRE SYSTEM AS INDICATED IN THE FOLLOWING PAGES.

MECHANICAL DATA

WEIGHT: 2KVA = 150 Lbs [68.2 kg]

SIZE: SEE DRAWING AT LEFT
 PAINT: SHERWIN WILLIAMS No. F737XA0853-4320
 COLOR: GRAY

THERMAL DATA

HEAT DISSIPATION @ 100% LOAD
 @ .8 LAGGING pf
 2KVA = 1365 BTU/HR MAX.

COOLING: FAN ASSISTED
 OPERATING AMBIENT= 32°F TO +122°F
 (0°C TO +50°C)

ENVIRONMENTAL DATA

NEBA 1= INDOOR DUTY, OPEN VENTILATED, NONCORROSIVE, CONTROLLED ENVIRONMENT PER UL1778, DOES NOT PREVENT ENTRY OF DUST.
 HUMIDITY RANGE: 0 TO 95% NON-CONDENSING
 ALTITUDE DERATING: NONE BELOW 7000 FT. 10%/1000 FT. ABOVE
 AUDIBLE NOISE: 50dB(A), 5 FT. IN FRONT OF UNIT, 4 FT. FROM FLOOR.

INSTALLER CONNECTIONS
 2KVA, 24VDC INVERTER SYSTEMS

DESIGN	DATE	DESIGN	DATE
DRAWN WALLACE	11-1-93	IC5194-020	
CHKD DATE	DATE		
APPD R. AMOROG	11-1-93	SHEET 1 OF 3	ISSUE

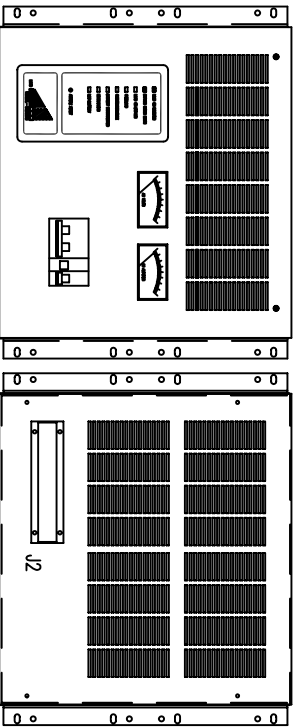

FRONT VIEW

REAR VIEW

NOTE: DC INPUT WIRING ENTERS INVERTER THRU CONDUIT KNOCKOUT ON LEFT SIDE OF ENCLOSURE. BYPASS AC INPUT AND AC OUTPUT WIRING ENTERS THRU CONDUIT KNOCKOUTS ON RIGHT SIDE OF ENCLOSURE.

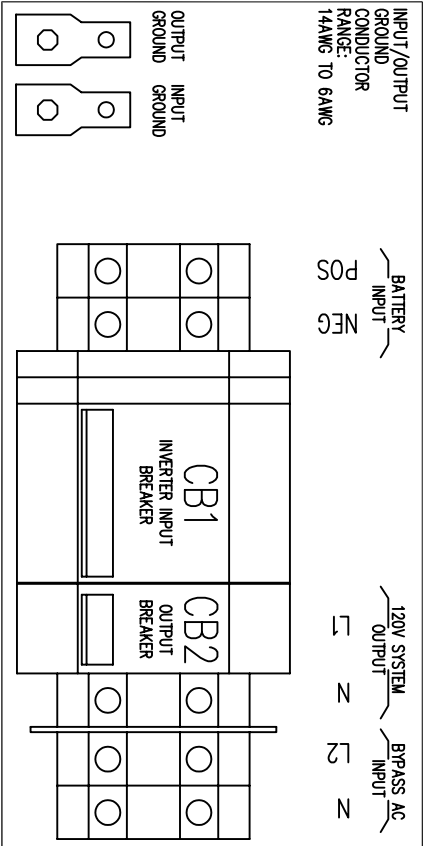

LOWER RIGHT, FRONT (INVERTER)

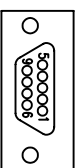

ALARM CONTACT PORT
SEE TABLE 1

RIGHT, REAR (INVERTER)

BYPASS AC INPUT	CONNECT TO
120V	L2 & N

INVERTER SYSTEM OUTPUT	CONNECT TO
120V	L1 & N

NOTE 1

TABLE 1	(J2) ALARM PIN No.
5	COMMON
6	ON BYPASS (N.O.)
7	LOW BATTERY (N.O.)
8	GEN. ALARM (N.O.)
9	UTILITY FAIL (N.O.)

NOTES:
1 NOT TO EXCEED CLASS 2 LIMITATIONS.
REFER TO N.E.C. ARTICLE 725-31,
TABLES (a) & (b).

2KVA (120V BYPASS INPUT, 120V OUTPUT)

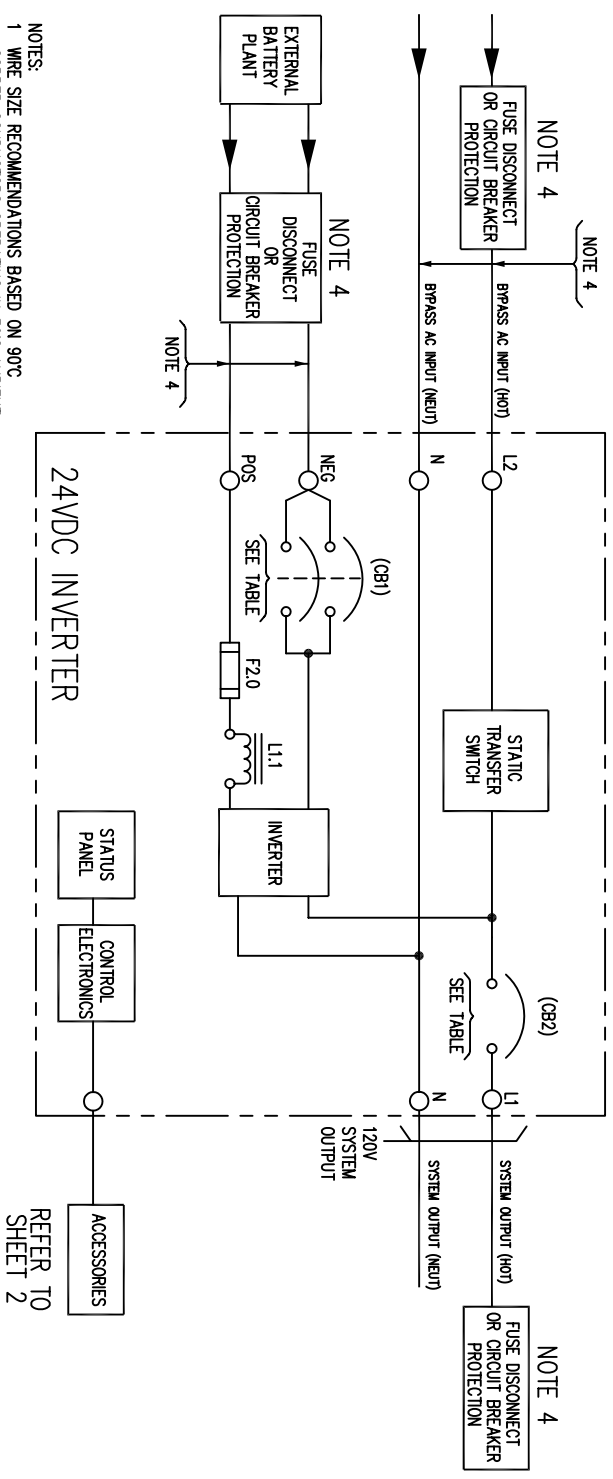

- NOTES:
- 1 WIRE SIZE RECOMMENDATIONS BASED ON 90°C COPPER CONDUCTORS OPERATING IN 30°C AMBIENT AND NEC TABLES 250-95 & 310-16, INCREASE CONDUCTOR SIZE FOR LONG RUNS.
 - 2 ALL FIELD WIRING TO BE COPPER CONDUCTOR ONLY.
 - 3 ALL GROUNDS SHOWN SHALL BE CONNECTED SEPARATELY TO A SINGLE GROUNDING POINT AT THE SOURCE SERVICE EQUIPMENT, PER IEEE STD. 446-1980 FIG. 72.
 - 4 FUSE OR CIRCUIT BREAKER PROTECTION EXTERNAL TO UPS TO BE PROVIDED BY CUSTOMER. SEE TABLE BELOW FOR RECOMMENDED PROTECTION SIZING AND WIRE SIZING.
 - 5 SPECIFIED TORQUE VALUES ARE FOR INTERNAL WIRING CONNECTIONS ONLY.

SIZE SPEC. No.	BYPASS AC INPUT						BATTERY LEAD						SYSTEM OUTPUT									
	AC INPUT	MAX. LOAD CURRENT	TERM.	TORQUE	RECOM. SIZE	RECOM. FUSING	(CB1) RATING	NOMINAL VOLTAGE	A.I.C. RATING	TERM.	TORQUE	RECOM. SIZE	RECOM. FUSING	OUTPUT VOLTAGE	FULL LOAD CURRENT (AMPS)	(CB2) RATING	A.I.C. RATING	TERM.	TORQUE	RECOM. SIZE	RECOM. FUSING	
2KVA	120	16.6 AMPS	12-2 AWG	35 IN/LB	10 GA	30A	80A (PARALLEL POLES)	24VDC	10,000	12-2 AWG	35 IN/LB	8 GA	150A	120V	16.6 AMPS	32A	10,000	12-2 AWG	35 IN/LB	10 GA	12 GA	30 AMPS