

POWER CONNECTION ACCESS COVER

DISPLAY PANEL

PHYSICAL INSTALLATION

- 1 POSITION SYSTEM IN FINAL LOCATION AND SECURE TO FLOOR WITH 3/8 HARDWARE (6 PLACES).
- 2 PROVIDE 36 INCHES OF SERVICE CLEARANCE ON EACH SIDE AND 12 INCHES AT THE REAR OF THE UPS. LOCATIONS NOT PERMITTING THE REQUIRED CLEARANCE SHOULD BE INSTALLED USING LIQUID-TIGHT FLEXIBLE METAL CONDUIT.

GENERAL NOTES:

- 1 ALL DIMENSIONS ARE IN INCHES UNLESS OTHERWISE SPECIFIED. DIMENSIONS WITHIN BRACKETS [] ARE IN CENTIMETERS.
- 2 WIRE SYSTEM AS INDICATED IN THE FOLLOWING PAGES.

MECHANICAL DATA

WEIGHT: 3KVA = 620 lbs [282 kg]

SIZE: SEE DRAWING AT LEFT
 PAINT: SHERWIN WILLIAMS PT. No. F631XA553-4337
 COLOR: LIGHT GRAY
THERMAL DATA
 HEAT DISSIPATION @ 100% LOAD
 3KW = 2.2K BTU/HR MAX

COOLING: FAN ASSISTED
 OPERATING AMBIENT= 32F TO +122F (0C TO +50C)

FOR MAXIMUM BATTERY LIFE, BATTERY MANUFACTURERS RECOMMEND AN OPERATING TEMPERATURE OF 77F (25C).

ENVIRONMENTAL DATA

NEMA 1= INDOOR DUTY, OPEN VENTILATED, NONCORROSIVE, CONTROLLED ENVIRONMENT PER UL1778.

HUMIDITY RANGE: 0 TO 95% NON-CONDENSING
 ALTITUDE DERATING: NONE BELOW 7000 FT. 10%/1000 FT. ABOVE
 AUDIBLE NOISE: 50dB(A), 5 FT. IN FRONT OF UNIT, 4 FT. FROM FLOOR.

INSTALLER CONNECTIONS

3KVA HARSH ENVIRONMENT

DESIGN	DATE	IC5196-331
DRAWN	DATE	
CHECKED	DATE	
APP'D	DATE	
SHEET 1 OF 3		ISSUE

BACK OF SYSTEM

(3) KNOCKOUTS FOR 3/4" CONDUIT



POWER CONNECTION ENCLOSURE
ACCESSED AND VIEWED FROM TOP OF SYSTEM

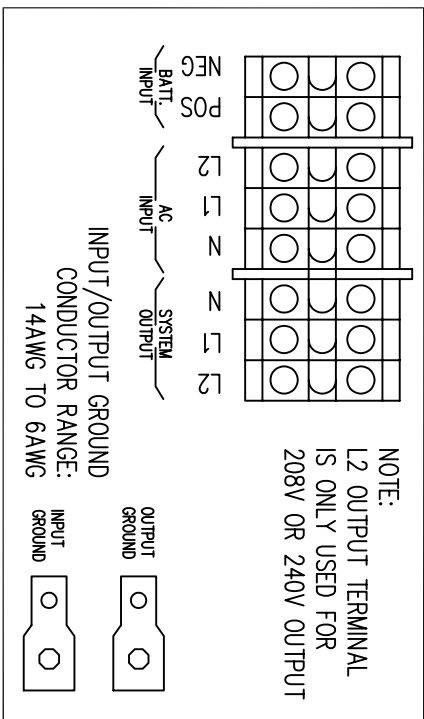

AC INPUT VOLTAGE	CONNECT TO	SYSTEM OUTPUT	CONNECT TO
208V	L1 & L2 & (N NEUTRAL)	120V	L1 & N
220V	L1 & L2 & (N NEUTRAL)	120/208V	L1 & N/L1 & L2
240V	L1 & L2 & (N NEUTRAL)	120/240V	L1 & N/L1 & L2
440V	L1 & L2 & (N NEUTRAL)		
460V	L1 & L2 & (N NEUTRAL)		
480V	L1 & L2 & (N NEUTRAL)		

MODEM PORT
STD. RJ-11 JACK
(PART OF RS-232
OPTION)

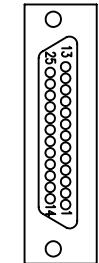

J1
RS-232 PORT
DB25S (FEMALE)
DCE CONNECTION
(OPTIONAL)

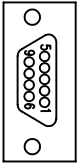

J2
ALARM CONTACT
PORT

(J2) PIN No.	ALARM
5	COMMON
6	ON BYPASS (N.O.)
7	LOW BATTERY (N.O.)
8	GEN. ALARM (N.O.)
9	UTILITY FAIL (N.O.)

NOTE 1

NOTES:
1 NOT TO EXCEED CLASS 2 LIMITATIONS.
REFER TO N.E.C. ARTICLE 725-31,
TABLES (a) & (b).

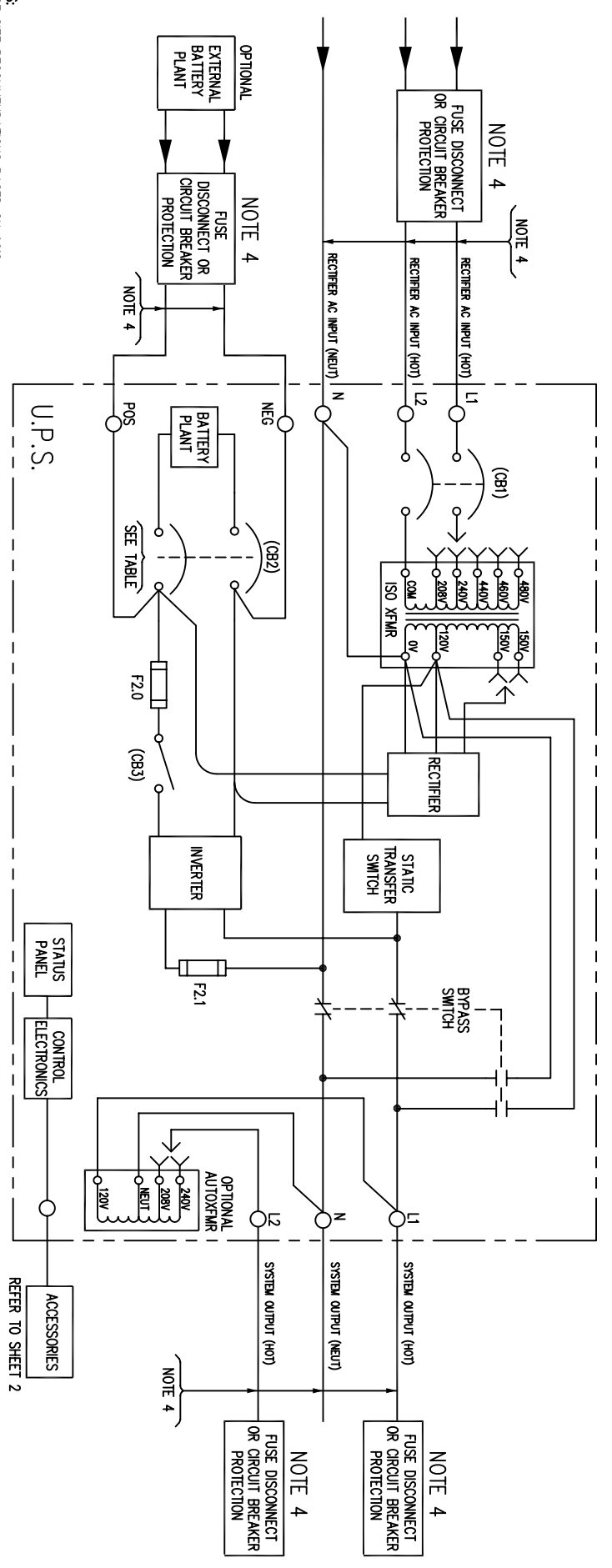

- NOTES:
- 1 WIRE SIZE RECOMMENDATIONS BASED ON 90°C COPPER CONDUCTORS OPERATING IN 30°C AMBIENT AND NEC TABLES 250-95 & 310-16, INCREASE CONDUCTOR SIZE FOR LONG RUNS.
 - 2 ALL FIELD WIRING TO BE COPPER CONDUCTOR ONLY.
 - 3 ALL GROUNDS SHOWN SHALL BE CONNECTED SEPARATELY TO A SINGLE GROUNDING POINT AT THE SOURCE SERVICE EQUIPMENT, PER IEEE STD. 446-1980 FIG. 72.
 - 4 FUSE OR CIRCUIT BREAKER PROTECTION EXTERNAL TO UPS TO BE PROVIDED BY CUSTOMER. SEE TABLE BELOW FOR RECOMMENDED PROTECTION SIZING AND WIRE SIZING.
 - 5 SPECIFIED TORQUE VALUES ARE FOR INTERNAL WIRING CONNECTIONS ONLY.

SIZE SPEC. No.	AC INPUT						BATTERY LEAD						SYSTEM OUTPUT								
	AC INPUT	MAX. INPUT CURRENT	(CB1) RATING	A.I.C. RATING	TERM. CAPACITY	TORQUE	TERM. No. (L1, L2, N)	(CB2) RATING	NOMINAL VOLTAGE	A.I.C. RATING	TERM. CAPACITY	TORQUE	TERM. No. (POS, NEG.)	OUTPUT VOLTAGE	FULL LOAD CURRENT (AMPS)	TERM. CAPACITY	TORQUE	TERM. No. (L1, N)	RECOM. SIZE	RECOM. GRD. SIZE	RECOM. FUSING
3KVA	208	21.4 AMPS	32A	10,000	12-2 AWG	35 IN/LB	8 GA	40A	120VDC	10,000	12-2 AWG	35 IN/LB	8 GA	35A	120/208/240V	25/14.5/12.5	12-2 AWG	35 IN/LB	8 GA	10 GA	35A/20A/20A
	220	22.4 AMPS	32A	10,000	12-2 AWG	35 IN/LB	8 GA	40A													
	240	20.6 AMPS	32A	10,000	12-2 AWG	35 IN/LB	8 GA	40A													
	440	11.2 AMPS	25A	5,000	12-2 AWG	35 IN/LB	12 GA	30A													
	480	10.9 AMPS	25A	5,000	12-2 AWG	35 IN/LB	12 GA	30A													
	490	10.5 AMPS	25A	5,000	12-2 AWG	35 IN/LB	12 GA	30A													

INSTALLER CONNECTIONS
 3KVA HARSH ENVIRONMENT SYSTEMS
 IC5196-331
 SHEET 3 OF 3