



Industrial 120VDC 3 & 5 KVA Inverter

Series 1000 Harsh Environment Inverter Standard Features

- Full kW-Rated Output Supports Any Power Factor Load - No Need To Oversize
- All Steel Enclosure with Gaskets and Reusable Air Filters
- High Efficiency Transistorized PWM Inverter
- Pure Sine Wave Output
- Less Than 1% Output THD
- Automatic "Zero Break" Transfer Switch
- Capable of Powering High-Inrush Loads
- Handles Nonlinear Loads With Up To 5:1 Crest Factors
- Load-rated at 50°C For Tough Industrial-Grade Protection
- Variable Speed, Temperature and Load Sensitive Cooling System For Quiet and Efficient Operation
- 20-year Designed Life
- User-Friendly Display Panel
- Internal Maintenance Bypass Switch
- Heavy Duty Floor Mount Brackets
- Built to Meet UL1778, NEMA, NEC, ANSI and FCC requirements



OPTIONS

- ⇒ Custom Voltage Outputs Available
- ⇒ 50Hz/60Hz Models
- ⇒ External Maintenance Bypass Switch (Rack or Wall Mount)
- ⇒ Caster Wheels
- ⇒ Drip Shield
- ⇒ PCB Conformal Coating
- ⇒ Form C Alarm Contacts
- ⇒ Digital Meter Panel
- ⇒ DC Ground Fault Detector
- ⇒ Surge Suppression
- ⇒ Dual Input Kit
- ⇒ Internal Battery Plant
- ⇒ AC Output Breaker
- ⇒ Network Communications Kit (System Status/Alarms/Temperature/Humidity)
- ⇒ ABS Testing and UL Certification

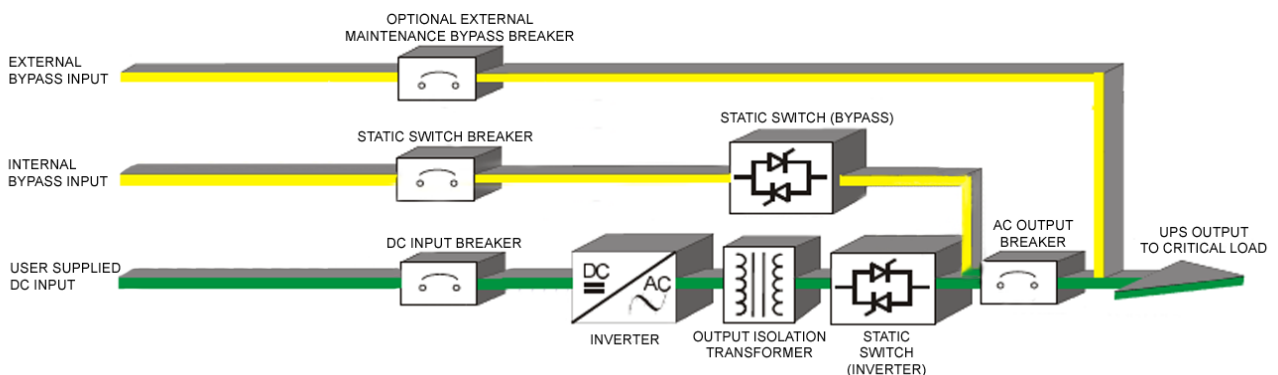



Industrial 120VDC 3 & 5 KVA UPS

Technical Specifications						
Model	D302CAHH			D502CAHH		
AC OUTPUT						
Power Rating (@ 40°C/50°C)	3.75kva (3kw) / 3kva (2.4kw)			6.25kva (5kw) / 5kva (4kw)		
Nominal Voltage 1Ph (V)	120	208	240	120	208	240
Nominal Current (A)	25	14.5	12.5	42	24	21
Frequency (Hz)	50 / 60Hz (Bypass freq. must match output freq.)					
Load Power Factor	Any					
Steady State Regulation	±1% over full input, power factor, temperature and load range					
Dynamic Regulation	±2% from nominal for 100% step load					
Harmonic Distortion	1% RMS max, for linear loads					
Load Crest Factor	5:1					
Overload Current @ 0.8 PF Load	110% Indefinitely					
	125% for 10 minutes					
	150% for 60 seconds					
Overload Current @ 1.0 PF Load	120% for 15 seconds					
	125% for 8 seconds					
Frequency Stability	±0.01% for nominal					
Slew Rate	1 Hz/sec max					
Sync Window	58.8 to 61.2 Hz (±2%)					
SYSTEM EFFICIENCY						
(Full Load)	>88%			>88%		
ENVIRONMENT						
Operating Temperature	32°F to 122°F (0°C to 50°C)					
Storage Temperature	-4°F to 140°F (-20°C to 60°C)					
Heat Dissipation (BTU/Hr)	1,800			2,700		
Humidity	0 – 90% non-condensing					
Audible Noise	< 65 dB(A) Scale @ 1 meter					
ENCLOSURE						
Model	D302CAHH			D502CAHH		
Dimensions	35"H x 18.75"W x 31"D			35"H x 18.75"W x 31"D		
Weight (lbs) w/o batt.	250			275		
Color	ANSI 61 Gray					
Cable Entry	Top Rear					
Rating	NEMA 12K					

Note: All data is subject to change without notice.